

Fall 2021

My First Book Club

Explore. Discover. Imagine. Share.



CANDLEWICK PRESS

• www.myfirstbookclub.com •

My First Book Club!

Candlewick Press and My First Book Club are committed to inspiring a love of books in young readers and bringing them together through shared reading, activities, and discussion.

Being part of a book club allows new readers to:

- **explore** new ideas and viewpoints
- **discover** connections with books and others
- **imagine** others' feelings and experiences
- **share** their own thoughts and opinions

More information about My First Book Club, including downloadable activities and discussion guides, is available at www.myfirstbookclub.com.

My First Book Club Picks



Book Buddies: Ivy Lost and Found
by Cynthia Lord
illustrated by
Stephanie Graegin

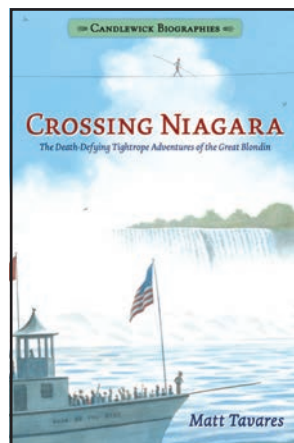

Crossing Niagara
by Matt Tavares



Sona Sharma, Very Best Big Sister?
by Chitra Soundar
illustrated by Jen Khatun

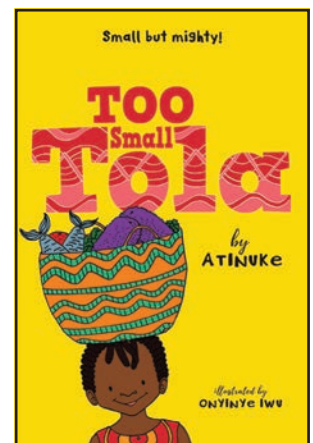

Too Small Tola
by Atinuke
illustrated Onyinye Iwu

Book Buddies



Ivy Lost and Found

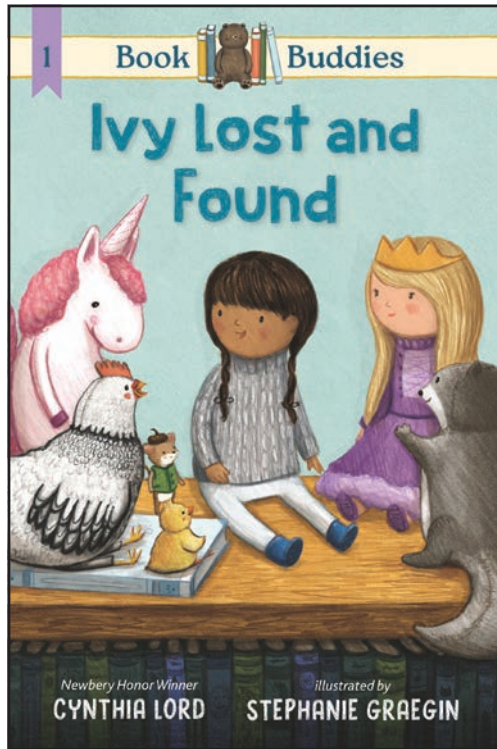

HC: 978-1-5362-1354-6

ABOUT THE CREATORS

Cynthia Lord is the author of award-winning middle-grade fiction titles such as the Newbery Honor Book *Rules*, as well as *Touch Blue*, *Half a Chance*, *A Handful of Stars*, and *Because of the Rabbit*. She is also the author of the Hot Rod Hamster picture book and early reader series as well as the Shelter Pet Squad chapter book series. Cynthia Lord lives in Maine.

Stephanie Graegin is the author-illustrator of *Little Fox in the Forest* and the illustrator of many other picture books, including *You Were the First* by Patricia MacLachlan and *Water in the Park* by Emily Jenkins. Stephanie Graegin lives in Brooklyn.

“A beguiling series opener that gently conveys the upside of adapting to unwelcome changes.”

—*Kirkus Reviews*

Don't miss the next Book Buddies adventure!



1. Ivy, a doll, meets some of the other Book Buddies, including a stuffed owl, a princess doll, a black bear, a tiny mouse, and a unicorn. Which Book Buddy do you think you would choose to take home with you?
2. When children arrive at the library, Ivy hides behind Dazzle because she doesn't want to be picked as a Book Buddy. Why do you think that is?
3. While they are stuck in the tree, Ivy and Piper realize that they feel braver with each other. Do you feel braver when you have a friend beside you?
4. Fern realizes that she has to talk to her siblings about how she feels and set boundaries. Why is it important to tell others how we are feeling?
5. By the time Ivy is returned to the library, she is happy to be a Book Buddy. Why do you think her feelings changed?



Do you have a stuffed animal, toy, or doll that keeps you company like the Book Buddies? Draw your special friend in the space below, then share with the group who you have drawn.



When a child takes home a Book Buddy, they are also given a journal in which to write about their time with their Book Buddy.

Using a separate sheet of paper and with the help of an adult, follow the instructions below to create your own Book Buddy notebook. Pick one of your toys or stuffed animals and have an adventure with them as if they were a Book Buddy. Then write or draw about what you did together in your journal.

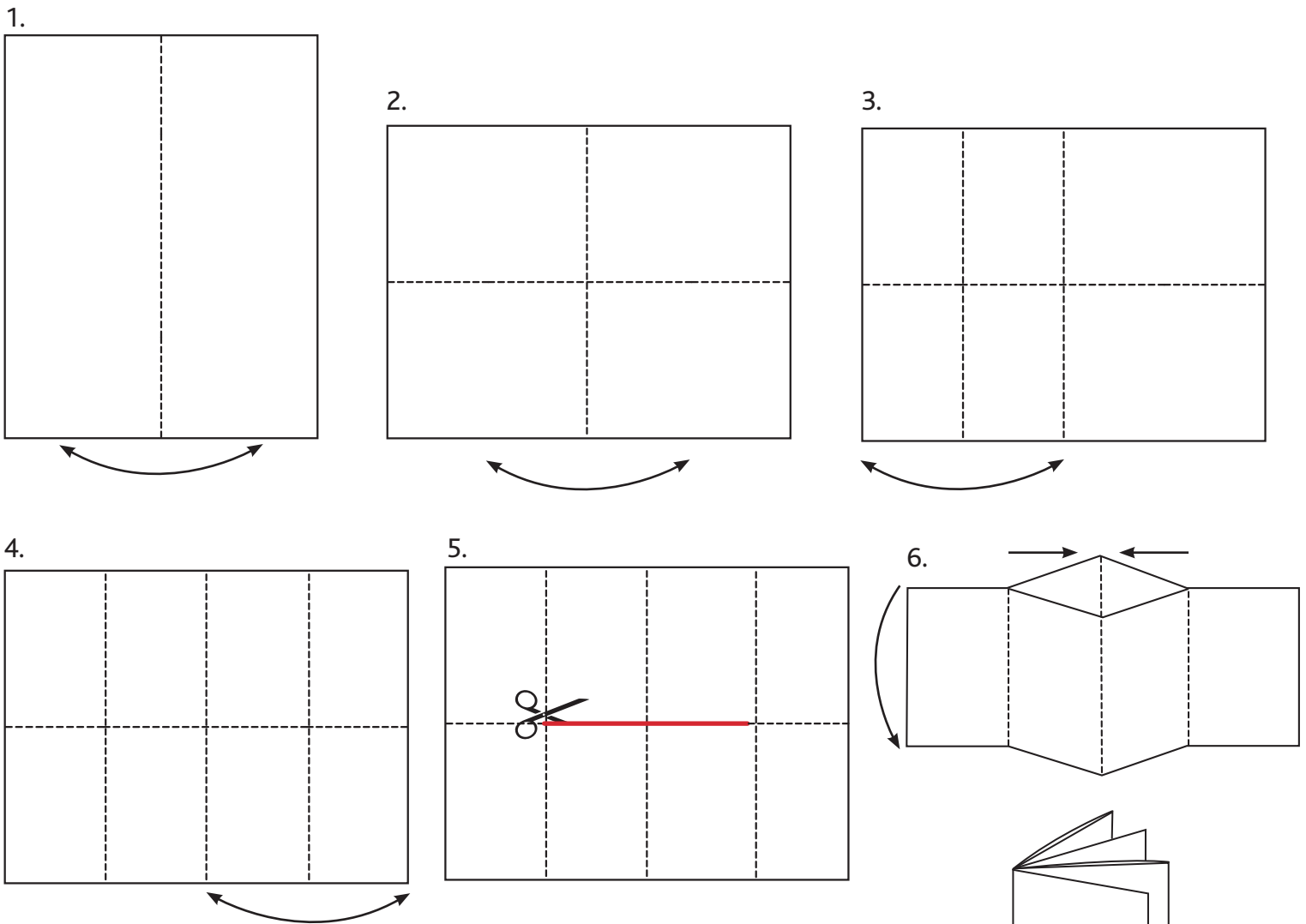

1. Fold and unfold the paper in half left to right.
2. Rotate paper, then fold and unfold in half left to right again.
3. Fold and unfold left edge to the center crease.
4. Fold and unfold right edge to the center crease.
5. Cut across the center crease in the two middle boxes (shown in red on the diagram).
6. Fold the paper top to bottom and push the ends together toward the middle.
Then fold all four pages to one side to finish the journal.

CROSSING NIAGARA

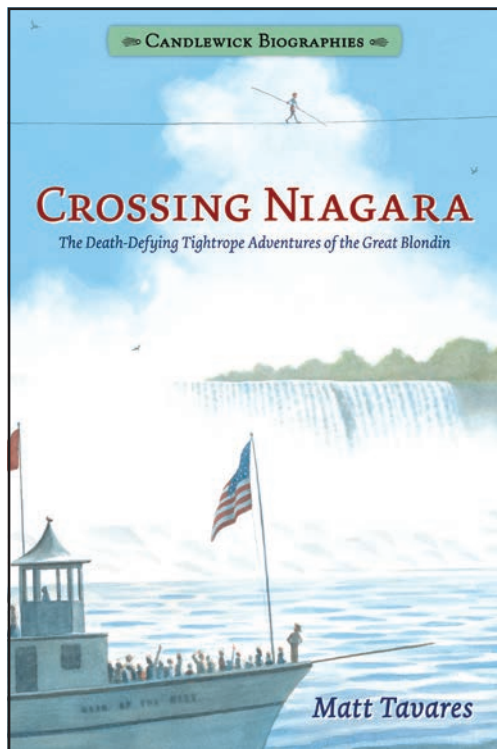

HC: 978-1-5362-0341-7 • PB: 978-1-5362-0342-4

ABOUT THE CREATOR

Matt Tavares is the author-illustrator of *Crossing Niagara*, *Henry Aaron's Dream*, *There Goes Ted Williams*, *Becoming Babe Ruth*, and *Growing Up Pedro*, as well as *Zachary's Ball*, *Oliver's Game*, and *Mudball*. He is the illustrator of *Twenty-One Steps: Guarding the Tomb of the Unknown Soldier* by Jeff Gottesfeld, *'Twas the Night Before Christmas*, *A Ben of All Trades: The Most Inventive Boyhood of Benjamin Franklin* by Michael J. Rosen, *Over the River and Through the Wood*, *Lady Liberty* by Doreen Rappaport, *The Gingerbread Pirates* by Kristin Kladstrup, and *Jubilee!* by Alicia Potter. He is also the creator of the modern Christmas tales *Red and Lulu* and the *New York Times* bestseller *Dasher*. Matt Tavares lives in Ogunquit, Maine.

“This would be an inspirational read-aloud for a unit on dreamers and adventurers—those daunting individuals who somehow make the impossible possible.” —*Booklist*

“A compressed, respectful glimpse at the achievements of a fascinating nineteenth-century daredevil.”
—*Kirkus Reviews*

“Tavares’s strength lies in his inviting watercolor, pencil, and gouache illustrations, which convey here the majesty of the waterfall and Blondin’s achievement, as well as the intensity of the hundreds of people who gathered to watch. . . . A simple but effective biography about a remarkable talent expressed through striking visuals.” —*School Library Journal*

If you liked *Crossing Niagara*, try these other Candlewick Biographies!



Lady Liberty
by Doreen Rappaport
illustrated by Matt Tavares

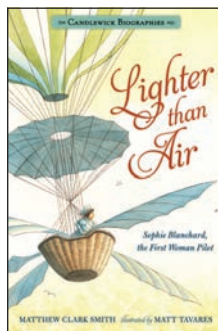

Lighter Than Air
by Matthew Clark Smith
illustrated by Matt Tavares



Vision of Beauty
by Kathryn Lasky
illustrated by Nneka Bennett

1. It must have been very scary to walk over a tightrope across Niagara Falls. Why do you think Blondin wanted to cross this place in particular?
2. Blondin secured his tightrope with guy ropes that kept the main line steady. Who or what supports you when you need a bit of help?
3. Blondin performed several tricks on the tightrope, including balancing on a chair, pushing a wheelbarrow, and carrying his manager on his back. Which trick would you have been most excited to see?
4. If Blondin had named you as the person he would carry on his back, would you have agreed to go?
5. In 1860, Blondin crossed Niagara Falls one last time. Even though he continued tightrope-walking, why do you think he was finished at Niagara?



Walking on a tightrope requires very good balance. Blondin walked across a tightrope that was over eleven hundred feet long—he had to balance for a long time! How good is your balance? Challenge the group to balance on the ground on one leg and see who can stay up the longest. What about on the opposite leg? Be sure to space everyone out and have an audience (spotter) to make sure everyone is safe. Balance on the ground only—anything higher is for professionals!

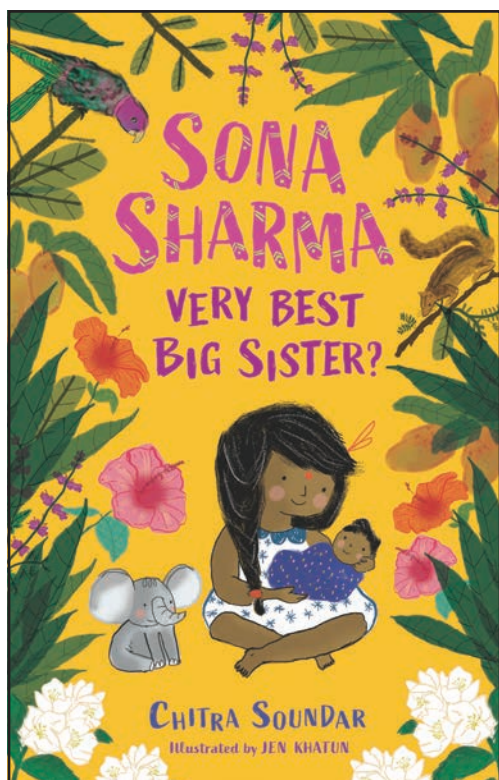

Illustration copyright © 2016 by Matt Tavares

Imagine that you were alive at the same time as the Great Blondin! Draw where you would have liked to have seen him stretch out his tightrope for another incredible, death-defying act.



SONA SHARMA, VERY BEST BIG SISTER?



HC: 978-1-5362-1482-6

ABOUT THE CREATORS

Chitra Soundar grew up in Chennai, India, in a multigenerational family that was filled with small fights, big laughter, and lots of stories. An award-winning author of more than forty books for children, she loves writing picture books, fiction, nonfiction, and verse. Chitra Soundar travels the world visiting schools and appearing at festivals to bring Indian stories to children everywhere. She lives in London.

Jen Khatun is an award-winning illustrator whose work incorporates whimsy and playfulness in each line. Based in England, she enjoys living close to the sea and regularly walks through the beautiful downs to fuel her creativity.

★ “This is a classic early chapter book, suitable for reading aloud as well as alone, with a gently humorous and imaginative style.”

—*The Bulletin of the Center for Children’s Books* (starred review)

“A charming story about becoming a big sister.”

—*Kirkus Reviews*



1. Sona feels a bit nervous and sad about her mother having another baby. Why do you think that is? If you are an older sibling, did you feel the same way as Sona?
2. Sona learns how babies receive their names and is reminded of her three names and what they mean. What is your full name? Do you know why you are named that?
3. Initially, Sona doesn't want to give up any of her baby things, such as her blue star dress. Why do you think she feels that way? Do you have any things from when you were a baby that are still special to you?
4. Sona's family uses many proverbs—phrases that teach a lesson, such as "Late peacocks miss the rain" (page 91). An example you may have heard is "The early bird catches the worm." Can you think of other similar sayings?
5. In the end, Sona is able to give her younger sister a name. Why does she choose Minmini?



The book begins with Sona listing her family and loved ones. Draw your family and share something about them with the group.



Sona lives in India and speaks Tamil, like the rest of her family. Can you find some of the words and names Sona and her family use? If you don't remember these words, check the glossary in the book!

A R A K K A N A K L A B
A C H E W B M K D T O M
N T P A N D H A L E U N
D K K R F A U L O O R A
A L A E H C H E L L A M
F I K A N A M C H T I A
V A R T U F V A D A O K
P O O R I V O A P T B A
L M A K S K O T A C H R
A N I L T H B U R I U M
H A F R S H I L N A M A
D O R F U T A S E S H X
A R U A D K U I P O D A
I M B A D A M E A D G M
B S L E O K N C L B T L
T R H R A K S H A S I H



- | | |
|-----------|----------|
| AKKA | PANDHAL |
| BADAM | POORI |
| BURFI | RAKSHASI |
| CHELLAM | TULSI |
| NAMAKARNA | VADA |

TOO SMALL TOLA

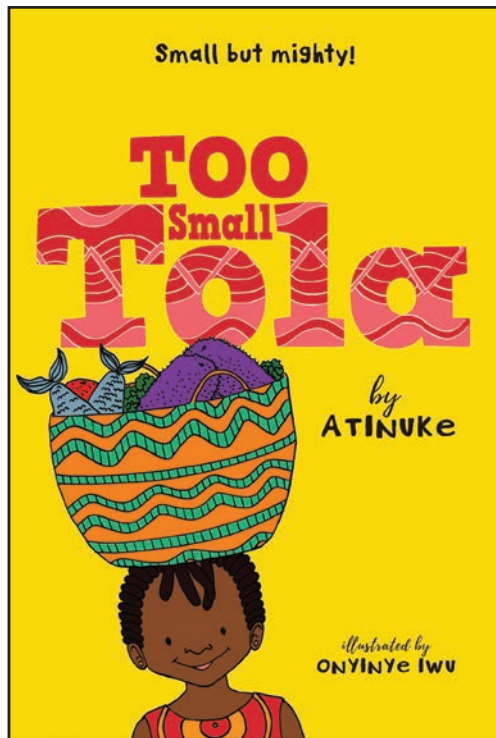

HC: 978-1-5362-1127-6

ABOUT THE CREATORS

Atinuke was born in Nigeria and spent her childhood in both Africa and the United Kingdom. She is the author of the Anna Hibiscus series and *Africa, Amazing Africa*, as well as *Baby, Sleepy Baby; Baby Goes to Market; B Is for Baby; and Catch That Chicken!*, which were illustrated by Angela Brooksbank. Atinuke lives in Wales.

Onyinye Iwu was born in Italy to Nigerian parents and moved to England when she was thirteen. She is a designer, illustrator, and educator. *Too Small Tola* is her first book for children. She lives in London.

- ★“Atinuke’s writing is rich with imagery and replicates the music and rhythm of Tola’s daily life. . . . The friendly format, universal emotional truths, helpful illustrations, and strong writing work together to immerse young readers in Tola’s world.” —*The Horn Book* (starred review)
- ★“This collection of stories is perfect for transitioning readers, with its manageable chapters, clear, plain language, simple sentence structures, wry sense of humor, and realistic illustrations of the diverse Nigerian cast. . . . An enjoyable, endearing collection.” —*Kirkus Reviews* (starred review)
- ★“Evoking all five senses to render contemporary Nigeria, the creators celebrate the beauty of daily life through Tola’s joy, wonder, and perseverance.” —*Publishers Weekly* (starred review)



1. Tola's family calls her Too Small Tola. Does your family have any nicknames for you? Do you have any nicknames for them?
2. Tola may be small, but she is still able to carry many market purchases on her head like her grandmother. Were you surprised that she was able to help out?
3. Everyone in Tola's family is good at something, like soccer, school, or counting. What are you good at? What is your favorite subject in school?
4. Tola proves that she can do many things even though she is small, such as carrying market purchases on her head, defending Mrs. Shaky-Shaky, and helping Mr. Abdul. Do you think that Tola's size matters? Why?
5. The book ends with Tola's family celebrating Easter and Mr. Abdul's family celebrating Eid. Do you celebrate either of those holidays? What is your favorite yearly celebration? Why?



At the Mile 12 Market, market women boast about their wares and shoppers haggle for the best deals. Grandmommy and Tola buy yams, leafy greens, red chili peppers, fish, rice, glue, diapers, and a computer mouse.

Host your own market. Have everyone bring in either a craft (friendship bracelets, handmade stress balls, painted pet rocks, etc.) or a snack they've made and set up a market. Establish prices. Everyone should receive the same amount of "money" in the form of stones, paper clips, buttons, or anything else that can stand in for currency. Then allow the group to shop at the market. They can haggle prices up or down or barter if they choose.



One of Mr. Abdul's clients tells Tola what kind of dress she would like by pointing to different parts of different dresses in a fashion magazine. Now it's time to design your own ensemble! Cut out different clothes and accessories from magazines to create a collage of an outfit or two that you would like to wear.

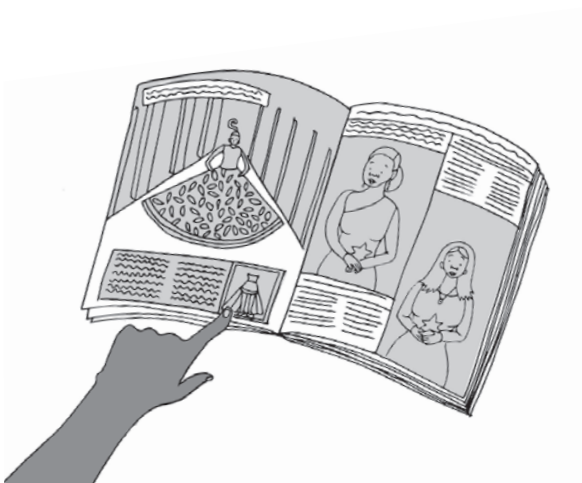



And Don't Miss the Previous My First Book Club Selections

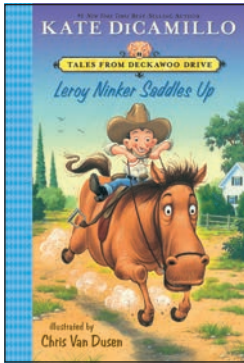

Leroy Ninker Saddles Up
by Kate DiCamillo
illustrated by Chris Van Dusen

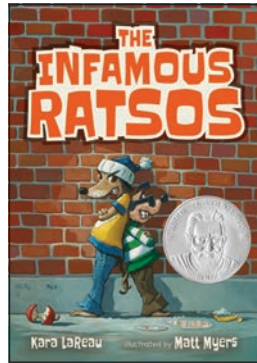

The Infamous Ratsos
by Kara LaReau
illustrated by Matt Myers

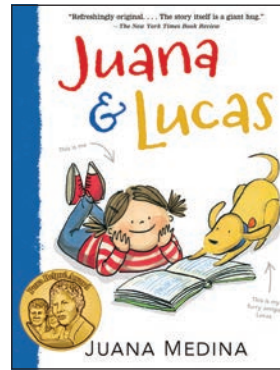

Juana & Lucas
by Juana Medina

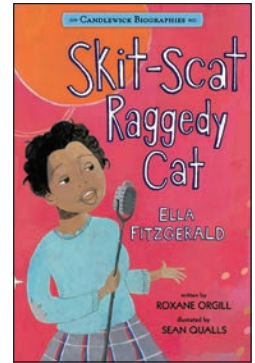

Skit-Scat Raggedy Cat
by Roxane Orgill
illustrated by Sean Qualls



The Princess in Black
by Shannon Hale and Dean Hale
illustrated by LeUyen Pham



Mercy Watson to the Rescue
by Kate DiCamillo
illustrated by Chris Van Dusen



Henry Aaron's Dream
by Matt Tavares



**Rocky Zang in
The Amazing Mr. Magic**
by Megan McDonald
illustrated by Erwin Madrid

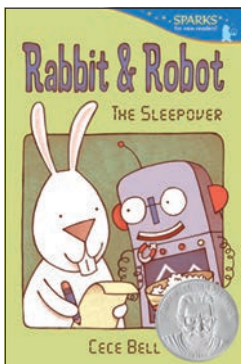

Rabbit and Robot: The Sleepover
by Cece Bell

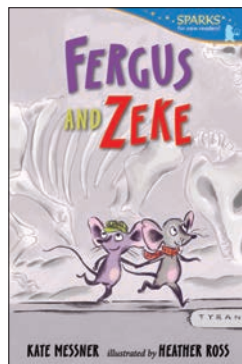

Fergus and Zeke
by Kate Messner
illustrated by Heather Ross

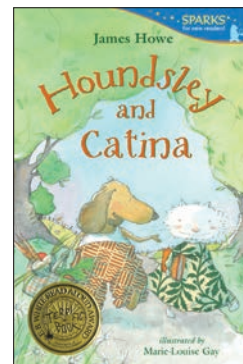

Houndsley and Catina
by James Howe
illustrated by Marie-Louise Gay

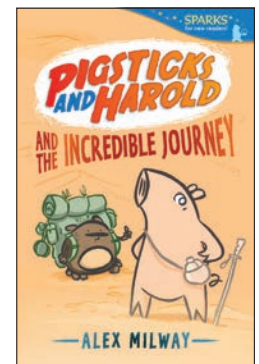

**Pigsticks and Harold and the
Incredible Journey**
by Alex Milway